



TruLaser Center 7030

The first full-service laser machine



TruLaser Center 7030

The first full-service laser machine:
Laser cutting and sorting of parts without any additional labor.

The TruLaser Center 7030 combines all laser cutting processes and significantly reduces throughput times and part cost. The need for post-processing is eliminated and excellent quality is achieved straightaway without microjoints and without risk of collisions. The automatic sorting function offers a great additional benefit, as it renders idle states for manual sorting unnecessary. The machine produces finished parts – so you can increase your production capacity without additional personnel thanks to less operator involvement and high automation.

Get a dynamic start

With the TruLaser Center 7030, the cutting head as well as the sheet metal moves. Thanks to the additional axis on the cutting head and overlapping axis motion, the machine is extremely powerful and achieves peak values in terms of cutting dynamics with up to 12 kW of optimally applied laser power.

Reliable parts automation

The machine ensures reliable parts handling thanks to integrated automation. Tipping and tilting of workpieces and using microjoints have now become a thing of the past.

Production around the clock with minimal staffing

When connected to your storage system, the full-service machine supplies itself with material and stores finished parts, which maximizes utilization. Around the clock, the machine relieves you of tiresome and monotonous work steps – this saves manpower and relieves the strain on employees.



Fast Reliable Automated Independent



Short film:
Simply explained
[www.trumpf.info/
bsaxpf](http://www.trumpf.info/bsaxpf)



A comparison of the process steps

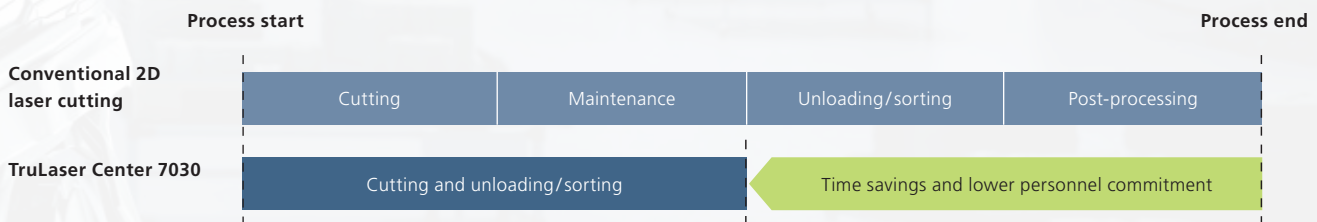

The result: the TruLaser Center 7030 takes care of all processes involving laser cutting safely and reliably – reducing your processing costs considerably.

Depending on the country, the available product range and data may differ from the details listed here. The technology, equipment, price and available accessories are subject to change. Please contact your local contact person to find out whether this product is available in your country.

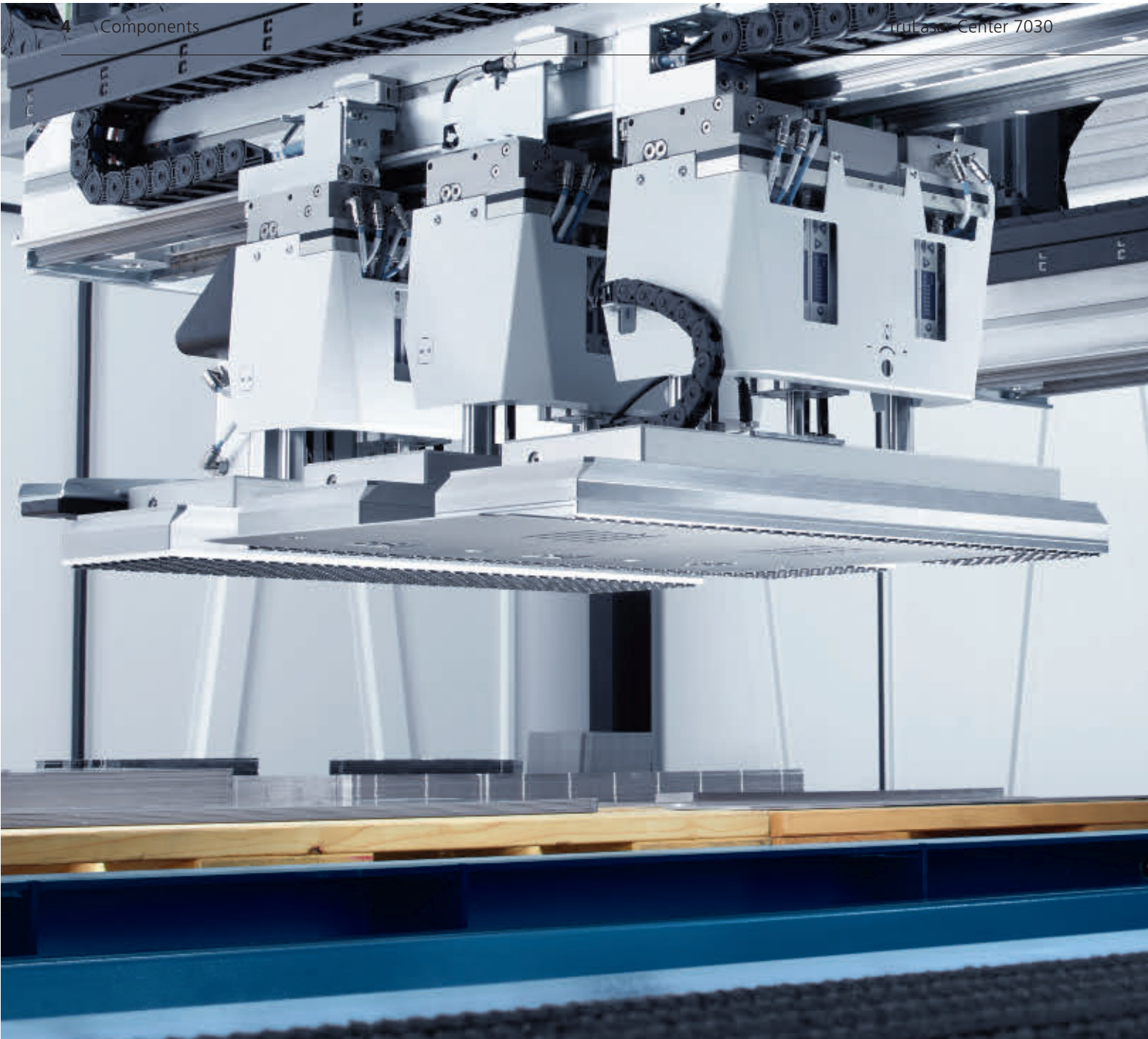

Redefining
automated laser
cutting

From now on, you can forget about rework due to microjoints and spatter: The full-service machine manufactures your parts in excellent quality and increases your production capacity. It is based on a machine concept that perfectly balances safe processes and high productivity. The following pages show the technical details that make the TruLaser Center 7030 so incredibly fast and yet so reliable.

Reliable

Reliable cutting and removal of parts

SmartGate:

Comprehensive part support

The SmartGate along with the brush table prevent the tilting and unwanted welding of parts. The intelligent support system moves along with the cutting head and provides complete support for your parts. The ejector cylinder automatically finds the best point to push the part out through the scrap skeleton. In the process, the part is fixed between the ejector cylinder and the SmartGate and is released from the scrap skeleton in a guided, downward movement. After this, the SmartGate opens and the part is reliably removed.

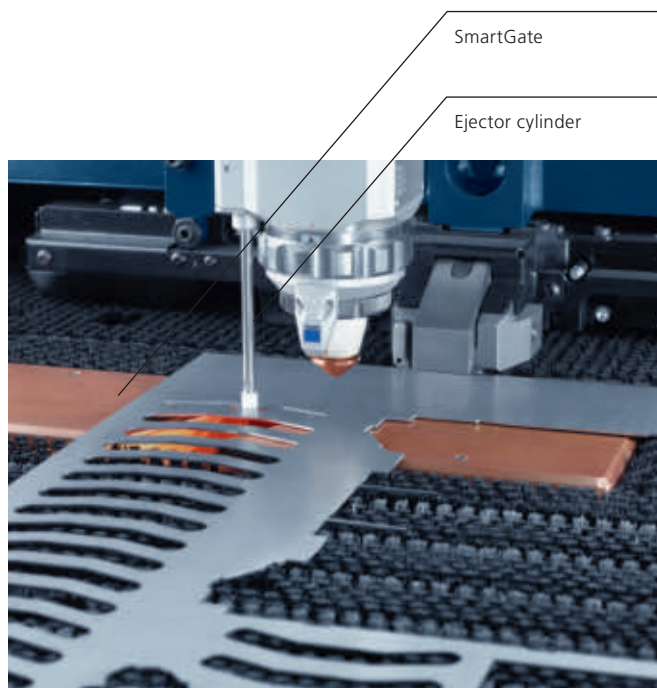

Parts are fixed between the ejector cylinder and the SmartGate, and are therefore removed with maximum process reliability.

SmartLift and SortMaster Speed:

Perfect part removal

The SmartLift and SortMaster Speed form a dream team, which is the fastest, most flexible automation system on the market. The cut-out parts are pushed upwards against the suction plate by the flexibly positionable pins of the SmartLift. At the same time, the suction plate of the SortMaster Speed fixes the part from above. Fixed in this way, the part is taken out of the scrap skeleton by a synchronous lifting movement. As such, the part is securely held and cannot tilt in the hole. The necessary flexibility comes from the self-activating suction cups of the SortMaster Speed, which can hold and stack even intricate parts with their 0.35 in. diameter.

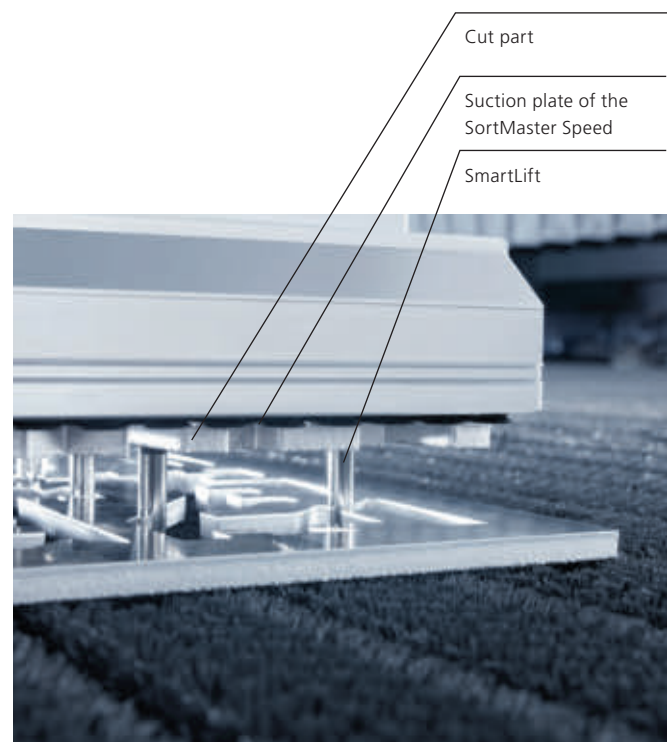

Process-reliable part removal: SortMaster Speed and SmartLift.

Fast

Highly dynamic cutting with a minimum of non-productive time

Optimal dynamics because of the superimposed axis movements

In the machine, the movement of the sheet and that of the cutting head are superimposed. The movement of the sheet is superimposed by the highly dynamic additional axis of the cutting head. This means that you cut corners and complex contours at high speeds. Thanks to this strong combination, you get the most out of the high feed rates of the solid-state laser.



SmartGate:

Automated removal of parts, slugs, and scrap within seconds

Within seconds, the SmartGate discharges small parts into up to eight containers. Slugs and scrap fall into a slag cart. Your key for maximum throughput: the removal of rest material causes only minimal interruption to the cutting process – a result of the intelligent control and sensor system of the SmartGate.

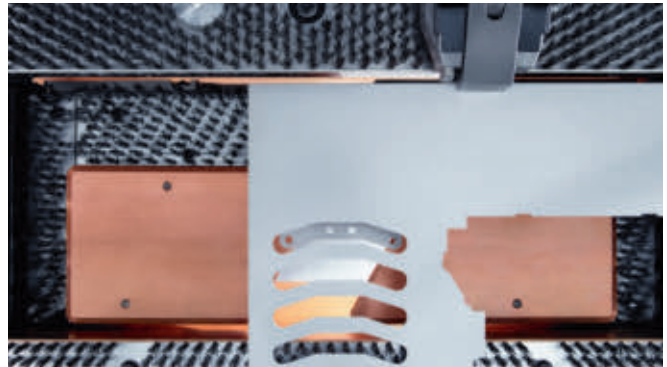

SortMaster Speed:

Part sorting in record time

The SortMaster Speed stacks parts at lightning speed and with perfect order directly on storage pallets or wooden pallets. As soon as the SortMaster Speed takes the part, the machine continues cutting. The part is taken to its deposit position parallel to production. Because of this there is only minimum interruption to the machining process.



Automated

Easily programmed procedures

Programming at the press of a button

The TruTops Boost programming system automatically creates a proposal not only for the cutting, but also for the removal, sorting, and palletizing of your parts. In doing so, it takes even physical principles into consideration. For example, how the part can best be pushed out of the scrap skeleton, to eliminate any chance of it tipping. This technique cannot be found anywhere else in the world.



Automated separation of finished parts and scrap

The integrated sorting flap reliably separates finished parts from scrap and slugs. The SortMaster Box Linear sorting unit distributes small parts into up to eight containers parallel to production. The containers are assigned intelligently by the software program.

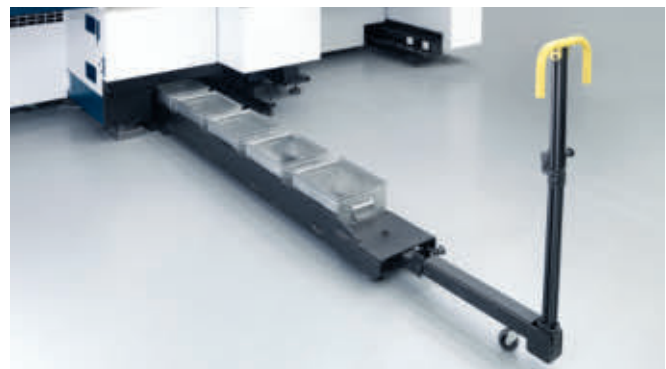

Self-reliant

Operator-efficient operation and plannable personnel deployment

Works reliably even during low-staffed shifts: The operator-efficient machine loads and unloads independently and announces when the operator is needed again. Because of this, the operator can plan their work at the machine better in advance. Waiting times, manual sorting, and post-processing are a thing of the past. The Touchpoint user interface also enables an intuitive dialog with the machine.



Working in perfect harmony for your success

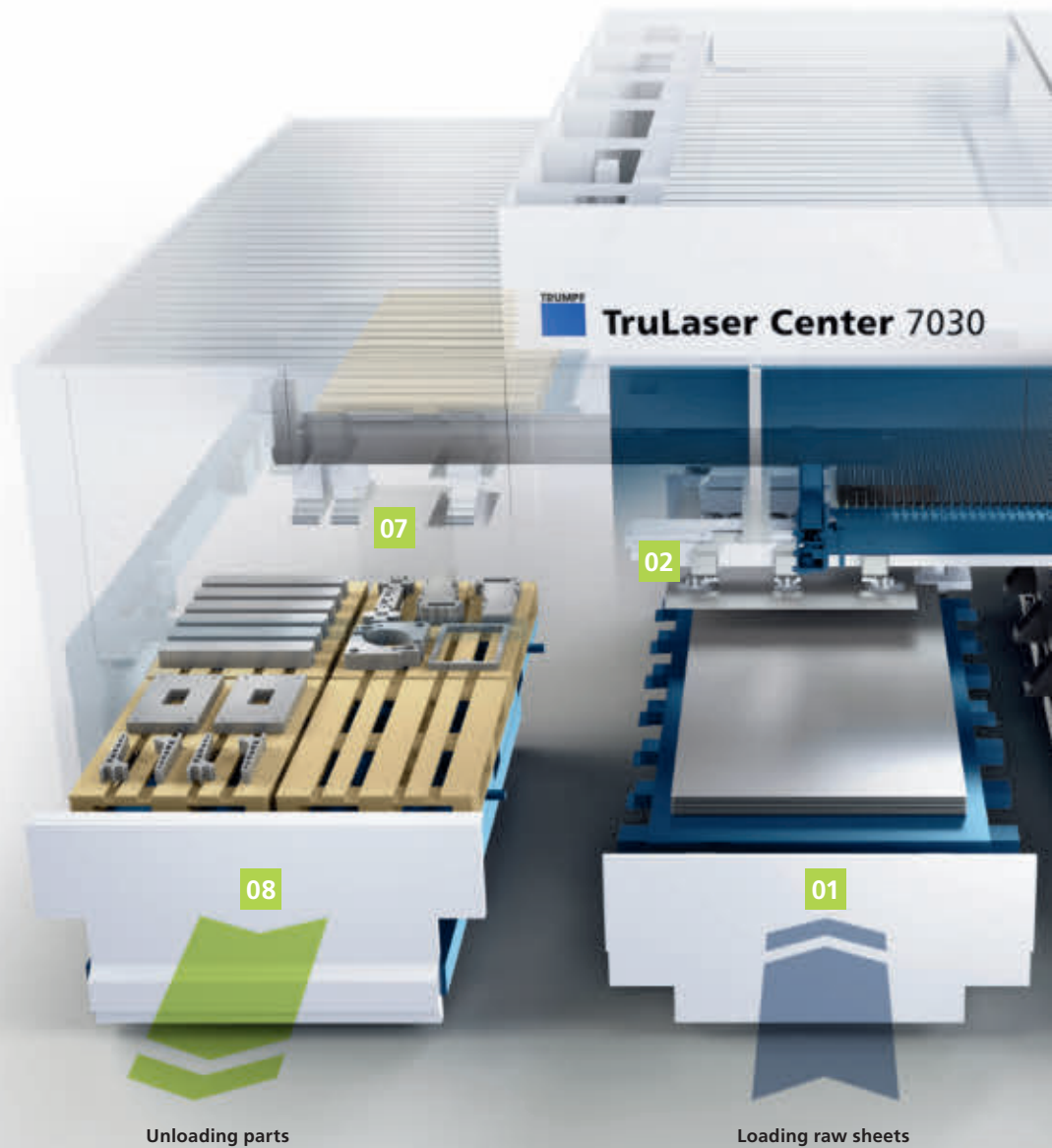

Programming an order

At the press of a button, the TruTops Boost programming system performs a fully automatic calculation for a comprehensive proposal for the cutting, removal, sorting, and depositing of your parts.

Loading raw sheets

The loading cart **(01)** can be loaded parallel to production. The LoadMaster Center **(02)** places the raw sheet on the brush table in the clamping unit. High-performance peeling techniques separate the sheet reliably from the stack.

Cutting parts

The clamping unit moves the sheet in the Y direction, the cutting unit **(03)** processes it in the X direction and also in the Y direction using a highly dynamic additional axis. The SmartGate supports the cutting process.

All process steps are interlinked, just like in a well-established team – allowing the TruLaser Center 7030 to overcome common laser cutting challenges and manufacture your parts in an incomparably cost-effective manner.

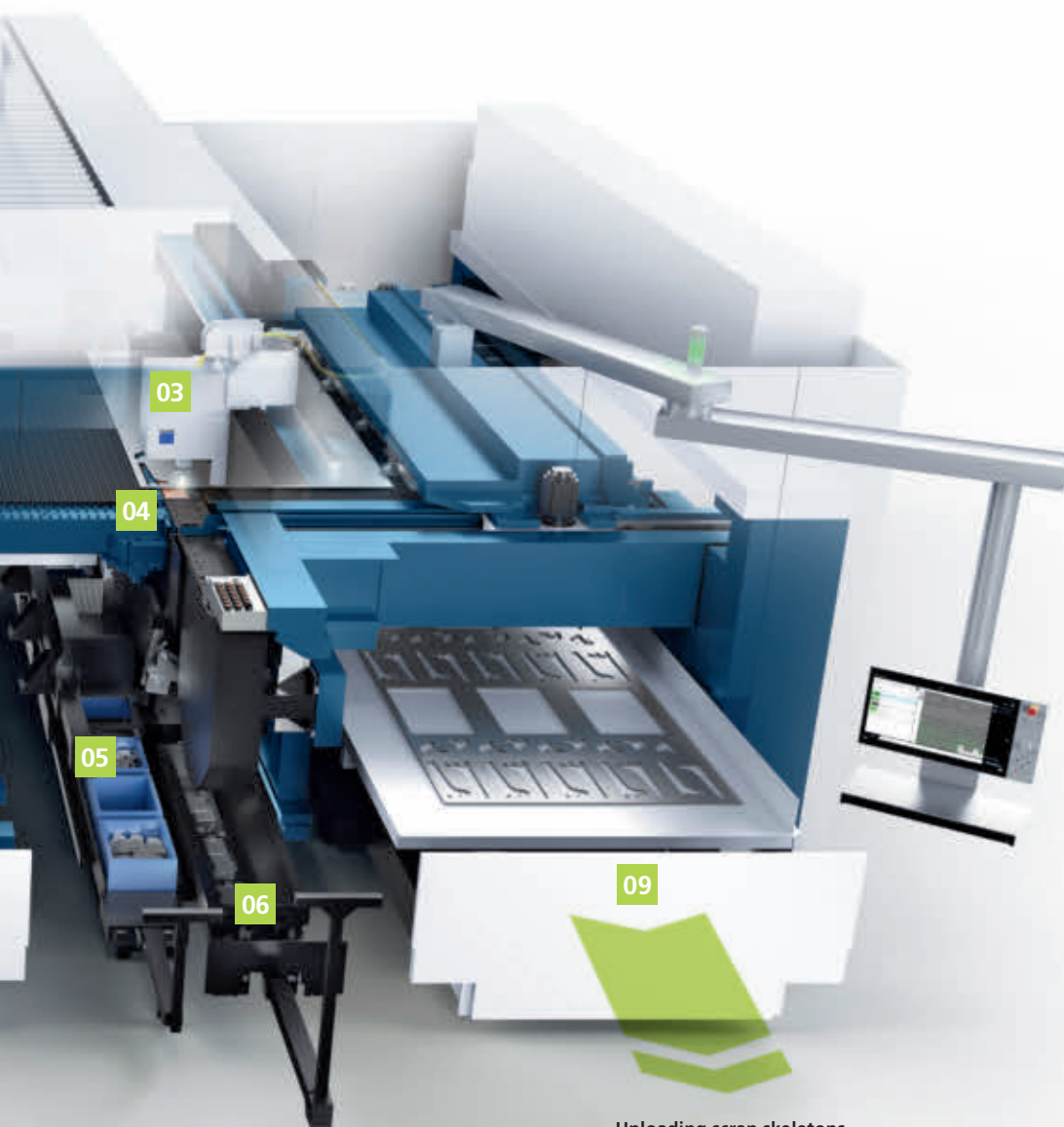

Unloading scrap skeletons

Removing parts and scrap

The SmartGate (04) removes slugs, scrap, and small parts reliably. The sorting flap separates finished cut parts from scrap. Finished parts are sorted into eight containers (05). Scrap and slugs fall into a slag cart or conveyor (06).

Unloading parts onto stacks

The SmartLift uses its pins to push the parts out of the scrap skeleton. The finely structured suction plates of the SortMaster Speed (07) remove the cut parts, and sort and stack them on the parts deposit. The suction plates and pins prevent any tilting of the parts.

Unloading finished parts and scrap skeletons

The parts (08) are removed from the machine, sorted, and stacked parallel to production. The clamping unit unloads the scrap skeleton onto the scrap skeleton cart (09). A forklift truck can empty this un rushed while the machine is operating.



See for yourself:
This is how the TruLaser Center 7030 works:
www.trumpf.info/xvnp0u



TruLaser Center 7030

The first full-service laser machine:
Laser cutting and sorting of parts without any additional labor.

01

Practically independent production

The compact machine performs the entire laser cutting process for you: It produces and sorts parts independently, day and night. This eliminates many time-consuming, tedious manual tasks.

02

High-quality production with process reliability

No spatter, no microjoints: the full-service machine produces high-quality parts with process reliability straight-away – without post-processing.

03

Easy programming

The TruTops Boost software makes programming easy: just a few clicks is all it takes to create reliable cutting and sorting programs.

04

Advanced sorting

Waiting times due to manual sorting processes? No, thank you: The SortMaster Speed removes and stacks both large and small components with delicate contours in the blink of an eye. The SmartGate ensures intelligent removal of even the smallest parts in a matter of seconds.

05

Increase production capacity

Thanks to the productive, dynamic full-service machine, you can take on more orders. You can increase your production capacity without additional personnel thanks to less operator involvement and high automation.

06

Reliable laser cutting

The automated overall concept prevents cutting collisions and parts from tipping. Stable processes are achieved through the additional axis, SmartGate, the brush tables and SmartLift, among other things.

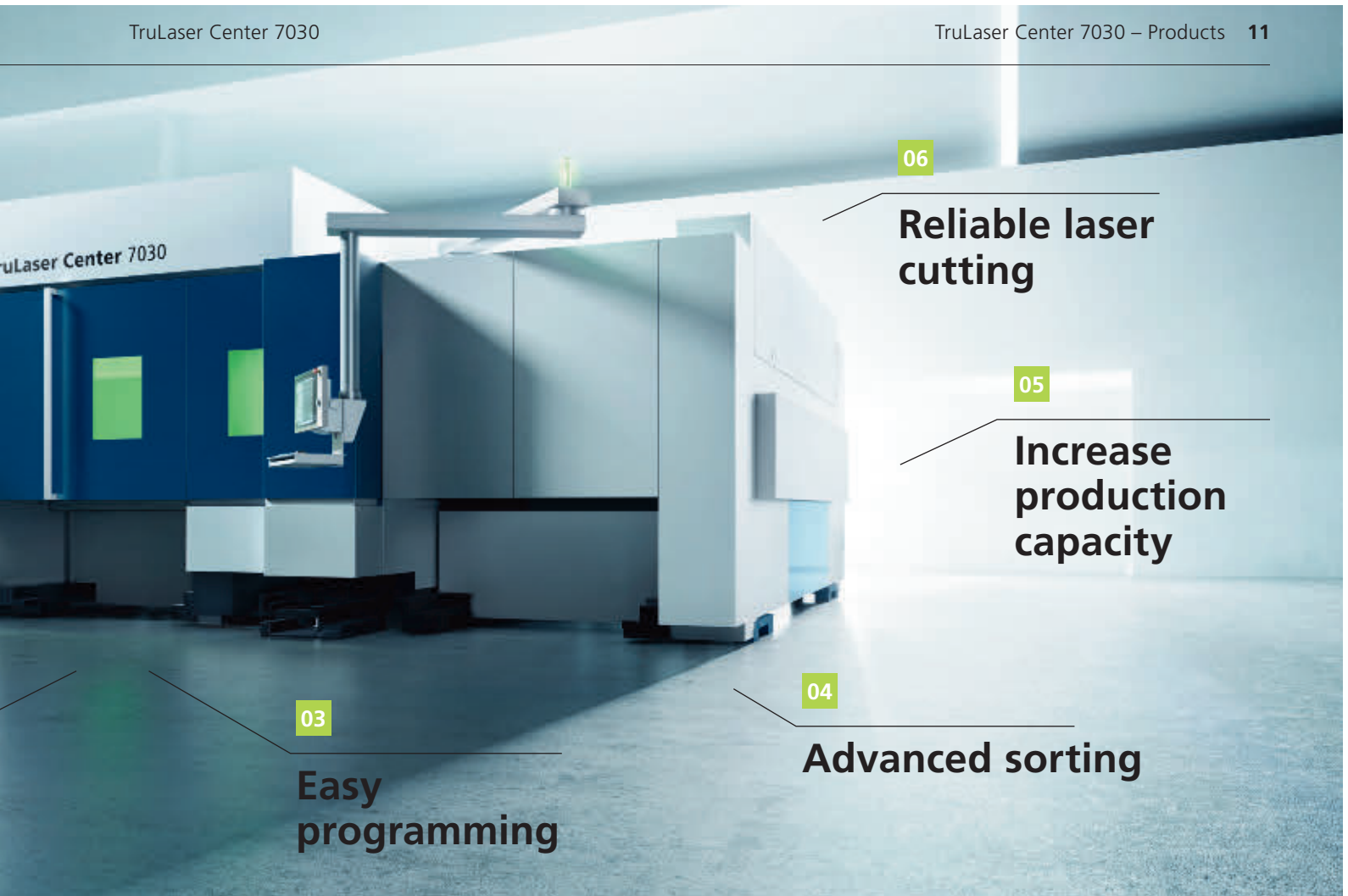

03

Easy programming

04

Advanced sorting

05

Increase production capacity

06

Reliable laser cutting

Technical data			TruDisk 6001	TruDisk 12001
Laser	Max. laser output	W	6000	12000
	Wavelength	µm	1.03	1.03
Machine dimensions^[1]	Length	in.	397.6	397.6
	Cart width, pushed in/pulled out	in.	256/394	256/394
	Height	in.	120.1	120.1
Loading	Max. sheet format	in.	120 × 60	120 × 60
	Min. sheet format	in.	39.5 × 39.5	39.5 × 39.5
	Max. raw material stack height	in.	5.1	5.1
	Max. loading capacity (standalone cart / storage pallet)	lbs	11,000 / 6,600	11,000 / 6,600
Unloading	Max. part weight with SortMaster Speed	lbs	265	265
	Max. part size with SortMaster Speed	in.	79 × 59	79 × 59
	Min. part size with SortMaster Speed	in.	3.5 × 2.4	3.5 × 2.4
	Available palletizing area (standalone / storage pallet)	in.	197 × 63 / 120 × 60	197 × 63 / 120 × 60
	Max. part size with SmartGate	in.	6.3 × 6.3	6.3 × 6.3
	Min. part size with SmartGate	in.	1.2 × 1.2	1.2 × 1.2
Max. sheet thicknesses	Mild steel	in.	0.04–0.4 ^[2] /0.5 ^[3]	0.04–0.5
	Stainless steel	in.	0.04–0.5	0.04–0.5
	Aluminum, copper, brass	in.	0.04–0.25	0.04–0.25

^[1] Approximate values. Dimensions including all of the modules and the safety areas. The exact data can be found in the respectively valid installation plan.

^[2] Fusion cut (N₂).

^[3] With BrightLine fiber.

Subject to alteration. Only specifications in our offer and order confirmation are binding.

Production around the clock

Utilize the enormous productivity of your full-service laser machine and connect the TruLaser Center 7030 to a store. Adapted to your material flow, the store supplies your machine around the clock with unprocessed material and can save finished parts.

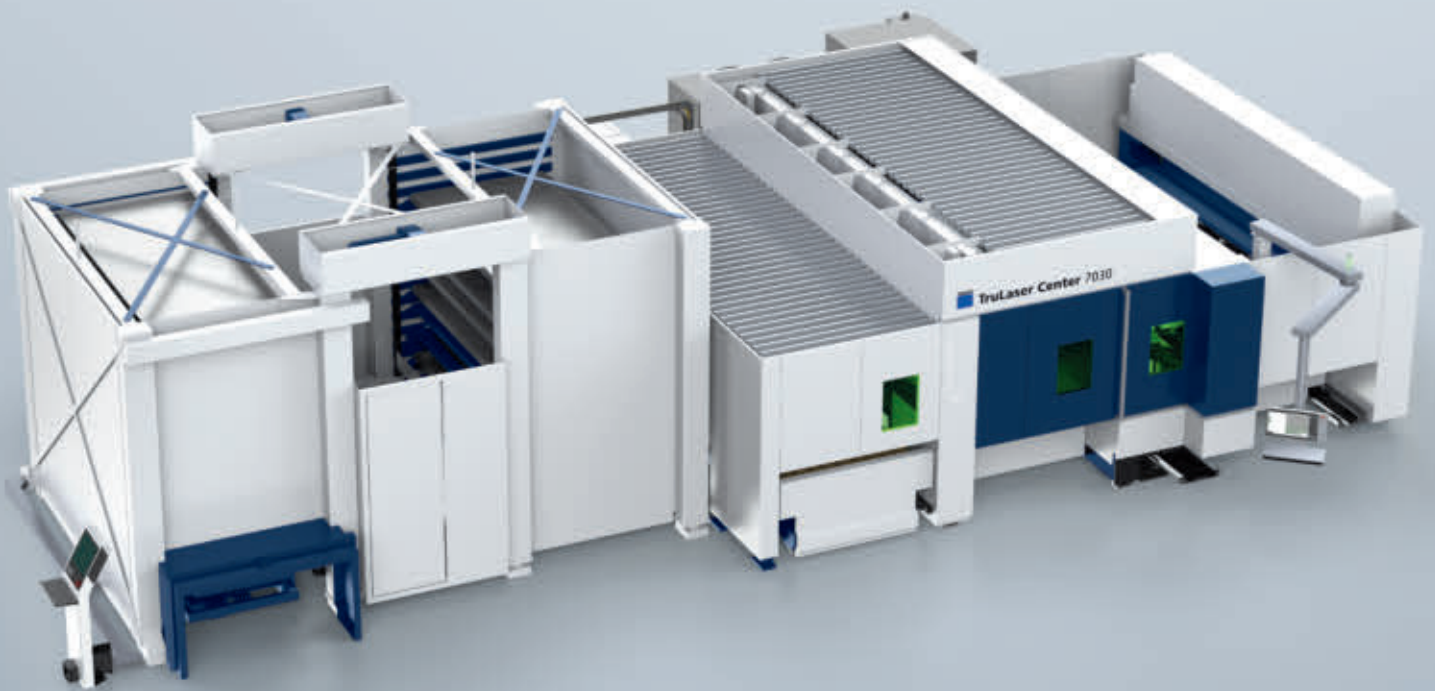

> Your advantage: You benefit from a higher machine utilization rate and low material access times.

Increase your capacity

Storage connection from the back for unprocessed material

Unprocessed material enters the machine via the rear side. Finished parts are stacked onto pallets and sorted into boxes. These can be accessed from the front of the machine.

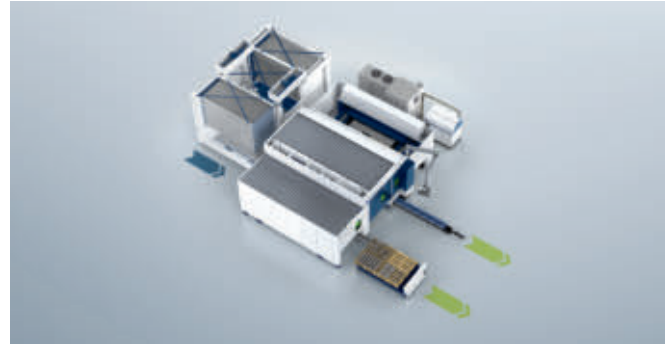

Side storage connection for unprocessed material

The unprocessed material is fed into the machine from the side. Finished parts stacked on pallets and small parts in boxes are fed out of the machine at the front.

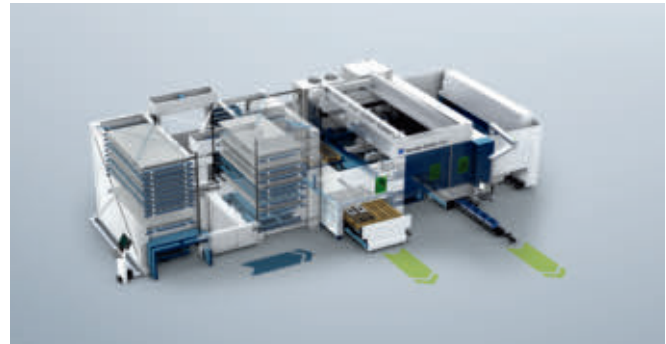

Side storage connection for unprocessed material and finished parts

The unprocessed material enters the machine from the side. Stacked finished parts are returned to the store on pallets, small parts are fed out of the machine at the front in boxes. A tandem changer enables direct access to the next pallet and reduces waiting times.

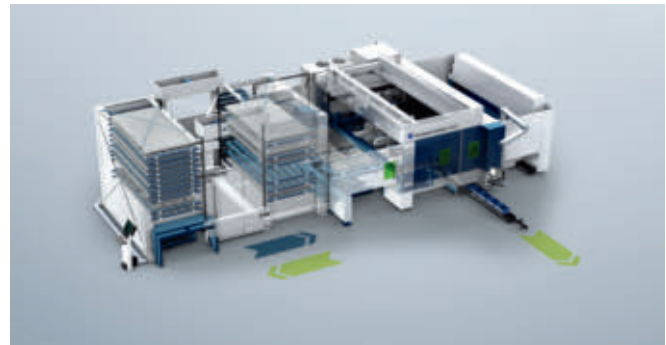

Side storage connection with flexible access to parts

The unprocessed material is fed into the machine from the side. You can handle finished parts with flexibility; unload these during the day at the machine, and place them back in the store at night. Remove the parts from the unloading cart directly, using an unloading base that is compatible for use with a forklift truck, or pallets.

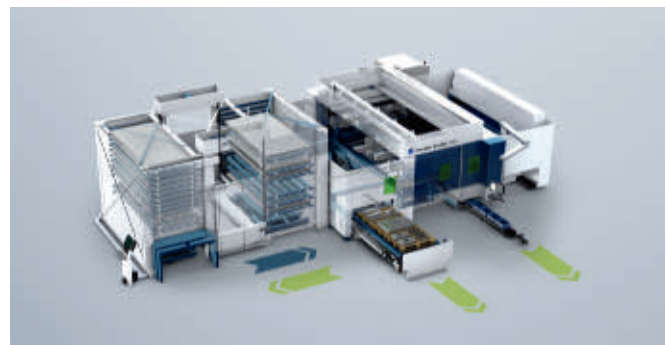

Side connection of large stores

You can connect your TruLaser Center 7030 to TruStore towers from TRUMPF as well as large-scale storage systems from STOPA. The modular STOPA system can be adapted to your requirements and expanded at any time.

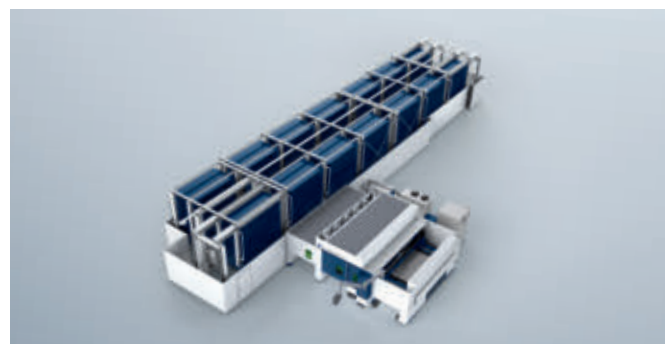

TruServices – Your partner in performance

By attending operator and programming courses, you can deepen your knowledge of laser cutting and gain a comprehensive understanding of how your TruLaser Center 7030 works and how to get the most out of your machine. It goes without saying that you can count on us during the installation and operation of your TruLaser Center 7030!

EMPOWER

Optimal preparation for smooth and quick commencement of production

SUPPORT

Application support customized to your needs.
Attractive financing offers with individual solutions

IMPROVE

Support from our application team for the first self-produced parts

TruConnect – Your Smart Factory

The TruLaser Center 7030 is a milestone on the way to the Smart Factory: It integrates all work steps for continuous laser processing in a single machine. TruConnect – synonymous with Industry 4.0 at TRUMPF – goes even further and optimizes processes outside the machine. Use the pragmatic solutions from TRUMPF to make your laser systems and your entire process more transparent, more flexible, and, above all, more efficient.

For companies big and small

From the simple product solution right through to fully networked production.

- **Getting started** with machines that are equipped for networking as standard
- **Improving gradually** with automated machines or autonomous processing cells embedded in a production solution
- **Entirely connected** with a continuous production solution, from the order to delivery

The perfect production flow with Oseon

Oseon combines production control with the advantages of a logistics system for the sheet metal sector – which is totally unique to date. You too can create your own perfect flow with the open software.



80%

of your production time is made up of indirect processes – this is where the greatest potential for saving lies.



Discover what potential networked production offers you with two example scenarios:



TRUMPF is certified to ISO 9001
(Find out more: www.trumpf.com/s/quality)



TRUMPF Inc.
www.trumpf.com