

TruMark Station 7000 with
TruMicro Mark Series 2000

Precise marking
made simple



Turnkey solution for marking with ultrashort pulses

All TruMicro Mark Series 2000 lasers have one thing in common: They combine extremely short laser pulses and outstanding beam quality to produce laser light of unparalleled brilliance. Whether your goal is reproducible, corrosion-resistant marking, high quality engraving, or extremely fine cutting, the TruMicro Mark Series 2000 offers the complete turnkey solution you need to process materials with ultrashort pulsed lasers.

The TruMicro Mark 2000 is available in a TruMark Station and as an OEM solution that includes the laser, scanner, cooling system and software, as well as the option of image processing. It is the perfect choice for producing laser markings with picosecond and femtosecond pulses.



This ensures defective parts are spotted and removed early on. The focus position of the camera and the laser can be set independently of each other, enabling laser machining and quality control to take place on multiple levels.

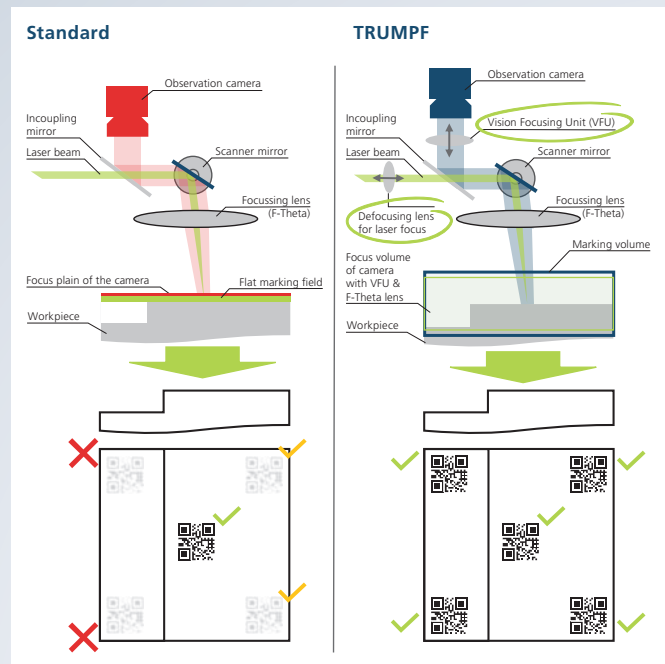

You'll be amazed at how many options you get with the new image processing system, regardless of whether the camera looks through the scanner lens or is installed to one side. You can choose between deploying one or two cameras. For example, you could use camera 1 to locate the right marking position on each new part while camera 2 is busy scanning and checking the mark on the previous part. You can rely on VisionLine to precisely adjust the system to your particular lighting conditions. And the stitching function lets you join together multiple high-precision images to improve machining accuracy even with the largest workpieces.

VisionLine comes with an intuitive user interface and a pre-defined attribute library, making it easier than ever to integrate VisionLine into your manufacturing process.

Maximum process stability and reproducibility

Maximum process stability for each individual pulse is guaranteed by the patented quadruple-loop feedback control system for internal online laser power measurement and regulation with single-pulse precision. This overcomes the hurdles of different frequency ranges, temperature fluctuations and age-related degradation processes. The closed-loop feedback control system produces perfectly machined parts over the entire service life, thereby ensuring optimum reproducibility.

Keeping an eye on process reliability

The modular VisionLine image processing software takes process reliability to a new level. It automatically detects the part's position and forwards this information to the control unit. This ensures markings are always applied in exactly the right position and makes it far easier to inspect and check the marked code. The system also alerts the user to parts that are missing, incorrectly inserted, or already marked.

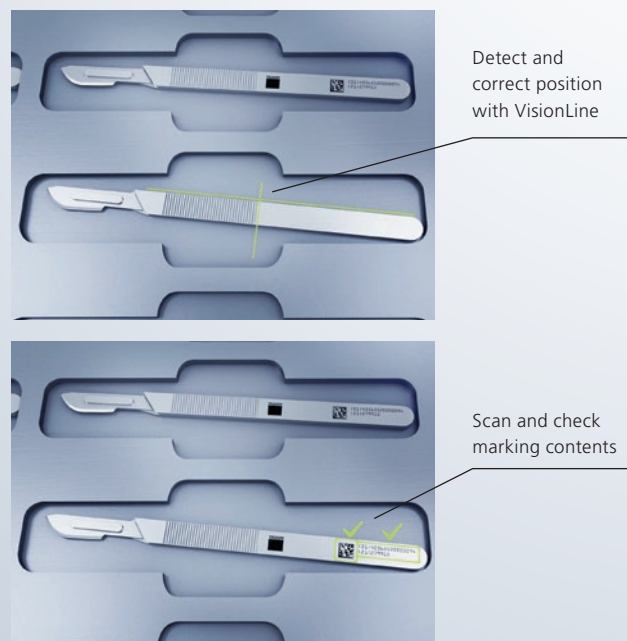

Medical device applications

The TruMicro Mark 2000 is a great choice for marking medical devices. It caters to a wide variety of applications:

- UDI-compliant marking in plain-text format and as a machine-readable bar code or Data Matrix Code to ensure traceability
- Micromarking in the hundredths of a millimeter range
- Microprocessing for structuring, cutting and drilling

Corrosion resistance is an essential attribute for implants and surgical instruments. Black marking offers an excellent way to achieve this.



Black marking – when durability really matters

Black marking is a laser processing method that creates extremely dark, high-contrast markings on a surface without material ablation. Extremely short laser pulses produce structures on the surface on the nanometer scale. The microstructured surface creates a light trap that significantly reduces light scattering. The result is a deep-black mark that maintains a high, even contrast whatever angle it is viewed from. If the laser pulses used for the marking process are ultrashort, the color changes also remain corrosion-resistant within certain parameter ranges. That's because the use of an ultrashort pulsed laser keeps the heat-affected zone extremely small, meaning that enough free chrome remains on the surface to allow the formation of a self-healing oxide film.

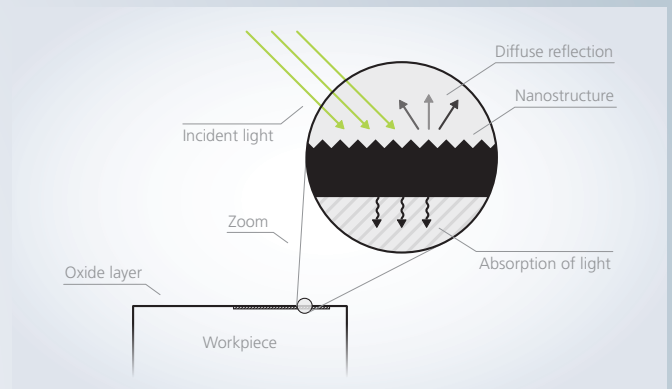

Turnkey solution for UDI marking

Our TruTops Mark Module Interface (TTM-MI) is a personalized software solution that can be set up to handle the whole UDI marking process.

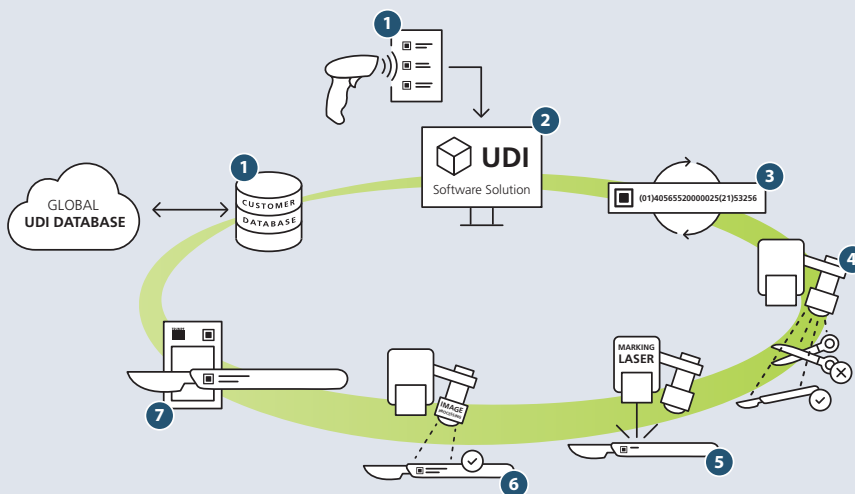

1. Access the database

The software is linked to databases, but information can also be fed into the system using external handheld scanners, for example.

2. Enter production data

The data is made available from the database or scanned in using a handheld scanner.

3. Generate UDI

The UDI module creates the UDI-compliant code from the UDI-relevant data and individual extensions.

4. Workpiece and position recognition

The VisionLine image processing system automatically identifies the component and detects its exact position and orientation. The software forwards this information to the control unit, which places the marking in the correct position.

5. Activate marking laser

The TRUMPF laser marks the workpiece with a permanent, corrosion-resistant, high-contrast marking that continues to be machine-readable and visible to the naked eye even after numerous cleaning cycles.

6. Optional: Detect code content

Quality control is easier than ever thanks to TRUMPF process sensors. TRUMPF image processing solutions can be used to detect and read UDI-compliant codes and check their quality using a variety of methods.

7. Optional: Check and compare marking data

The system compares the marking content with the corresponding data in the database and stores it for documentation. Where necessary, it can also record additional information such as the content and quality assessment of the UDI code or the machines involved in the process. This ensures the components and their markings remain fully documented for several years.

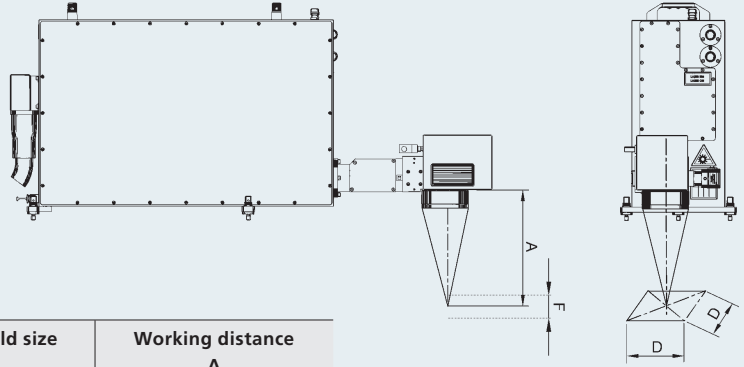
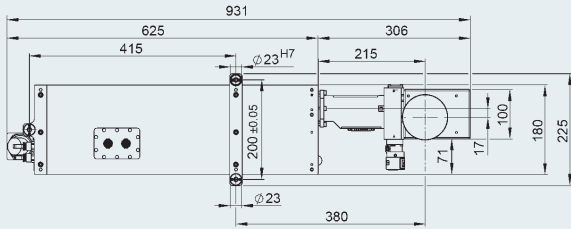

Focal length of the fθ lens	Internal defocussing of the laser F	Marking field size D x D	Working distance A
100 mm (telecentric)	± 5 mm	60 x 60 mm ²	210.6 mm
160 mm (standard)	± 15 mm	110 x 110 mm²	212.6 mm
255 mm	± 40 mm	180 x 180 mm ²	359.0 mm

TruMicro Mark 2000

Product variants	TruMicro Mark 2030 (L038) 20 ps Picosecond version	TruMicro Mark 2030 (L038) 900 fs Femtosecond version
Wavelength	nm	1030
Average power	W	20
Pulse duration	ps fs	20 900
Max. pulse energy	μJ	20
Pulse repetition frequency	kHz	05–1000 (optionally 2000)
Marking volume	mm ³	60 x 60 x 10 110 x 110 x 30 180 x 180 x 80
Beam quality of beam source	M ²	< 1.3 TEM ₀₀
Optional fieldbus interfaces	EtherCAT, Profibus, Ethernet/IP, Profinet	

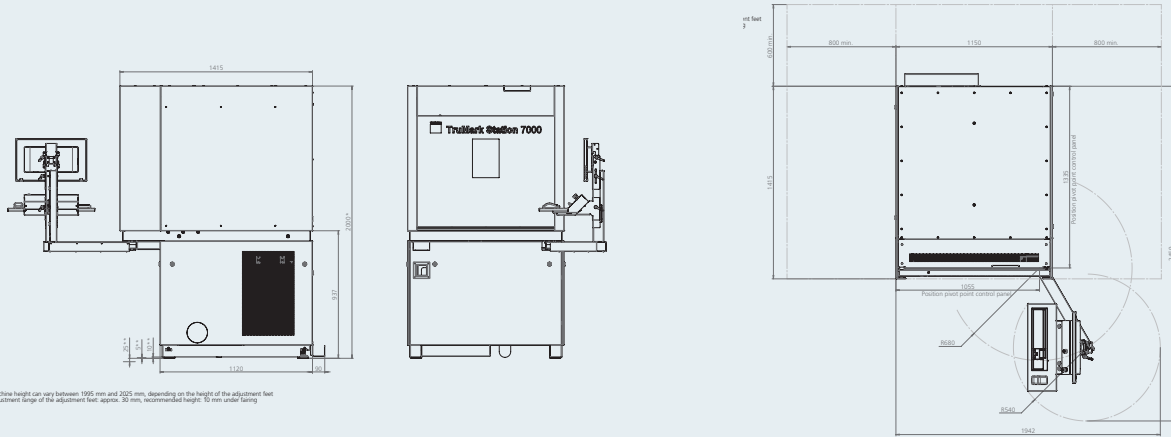

* Machine height can vary between 1995 mm and 2025 mm, depending on the height of the adjustment feet

** Adjustment range of the adjustment feet: approx. 30 mm, recommended height: 70 mm under loading

TruMark Station 7000

Dimensions	mm	1415 x 1015 x 2000
Max. workpiece weight	kg	100 kg / 50 kg (with Y-axis)
Travel range of X Y Z axes	mm	650 350 330*

* Depending on the focusing optics used.

Subject to alteration. Only specifications in our offer and order confirmation are binding.

TRUMPF Laser- und Systemtechnik GmbH

Johann-Maus-Strasse 2 · 71254 Ditzingen · Phone +49 (0)7156 303-30862 · Fax +49 (0)7156 303-930862

E-mail info@trumpf.com · Homepage www.trumpf.com

